

TECHNICAL DATA SHEET

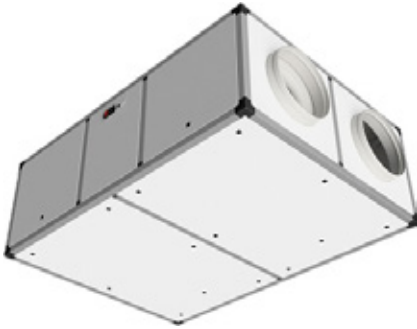

PRODUCT CODE	TYPE OF CONTROLLER	VERSION	DIMENSIONS (WxHxD) mm
701HR12H1EB0002	Smart EB	H1 horizontal, ceiling mounting	1607x521x1100
701HR12H13E0000	Easy 3E		
701HR12B1EB1002	Smart EB	B1 horizontal, floor-standing, outdoor	1688x652x1298
701HR12B13E1000	Easy 3E		
701HR12V1EB0002	Smart EB	V1 vertical, floor-standing	1607x1200x521
701HR12V13E0000	Easy 3E		
701HR12V1EB1002	Smart EB	V1 vertical, floor-standing, outdoor	1691x1415x723
701HR12V13E1000	Easy 3E		

TECHNICAL DATA

- Flow rate up to 1740 m³/h, head up to 1480 Pa
- Counterflow heat recovery unit, aluminium, with efficiency >90% (Erp-2018), Eurovent certified
- EC fans, centrifugal backward-curved blades, low consumption
- Low pressure drop filters: F7 (ePM1 70%) for fresh air and M5 (ePM10 50%) for extraction
- Aluminium profile and sandwich panel structure (pre-painted sheet metal outside, galvanised sheet metal inside)
- Rock wool thermal/acoustic insulation, 25 mm thick
- Nominal voltage: 230 V 1F 50-60 Hz Max. absorption: 4,6A 1,1kW
- Overall dimensions excluding ducts and condensate drain (w x d x h): 1491x1100x521 mm
- Nominal pipe diameter: Ø 315 mm
- Weight: 188 kg
- Integrated bypass for free-cooling / free-heating (manual, motorised or automatic operation)
- Horizontal or vertical configuration, air duct orientation can be changed on site
- Available with the following controls: 3-speed Easy 3E, electronic with white LCD display Smart EB
- Integrated frost protection
- Operating conditions: ambient temperature between 0 °C and 45 °C, humidity <80%
- Standard indoor installation with possibility of outdoor installation*: fresh air temperature -7 °C** to +40 °C

* supplied with IP55 control panel and rain canopy; condensate drain insulation required.

** for lower temperatures, the use of an antifreeze heater is recommended.

AVAILABLE CONTROLLER



Easy 3E - Electronic control/connection board installed on board the machine; remote control with on/ off, speed selection from 3 preset speeds (speed calibration can be changed using trimmers on the board), opening/ closing signalling (it is possible to modify the speed setting by acting on the trimmers on the board), by-pass opening/closing signalling (with automatic control), anti-blocking protection signalling. Closure by-pass signalling (with automatic control), frost protection signalling (with automatic control by reducing the fan speed). By reducing the speed of the inlet fan), dirty filters signalling (counting of operating hours) and hours of operation

and temperature probe failure. Possibility of controlling the unit through simple digital inputs (on-off and remote speed). The remote control can be installed inside a type 503 horizontal box. Possibility of (automatic) control of a possible antifreeze heater (even 2 stages).



Smart EB - Electronic control/connection board installed on the machine, which can be combined with a thin white LCD display, with integrated humidity and ambient temperature probes (can be installed on a type 503 horizontal box); fan speed can be selected manually from 3 preset speeds (modifiable from 10% to 100%) or managed automatically by the control board (depending on humidity, air quality, temperature and/or other external probes); possibility of differentiating the speed of the inlet fan with respect to the exhaust fan; automatic control of the by-pass, with both free-cooling and free-heating functions; integrated frost protection with reduction in the speed of the inlet fan or, if present, with an anti-freeze resistor; automatic

management of any post-treatment batteries/resistors (both with on/off and 0-10V valves); display of any active alarms and alarm history; filter clogging alarm both with counting of operating hours and with differential pressure switches; hourly/weekly programming. Possibility of controlling the control board with simple digital inputs (remote on/off contacts, speed, summer/winter...) and of combining it with external 0-10V probes (CO2/air quality, humidity, temperature, constant flow rate/pressure control...); ModBus on RS485 for connection to external controllers/supervisors; provision for expansion modules (LAN, RS485, RS232, GSM...), available in the future

TECHNICAL DATA SHEET

POSSIBLE CONFIGURATIONS

-  FRESH AIR INLET
-  EXHAUST AIR
-  STALE AIR EXTRACTION
-  SUPPLY AIR

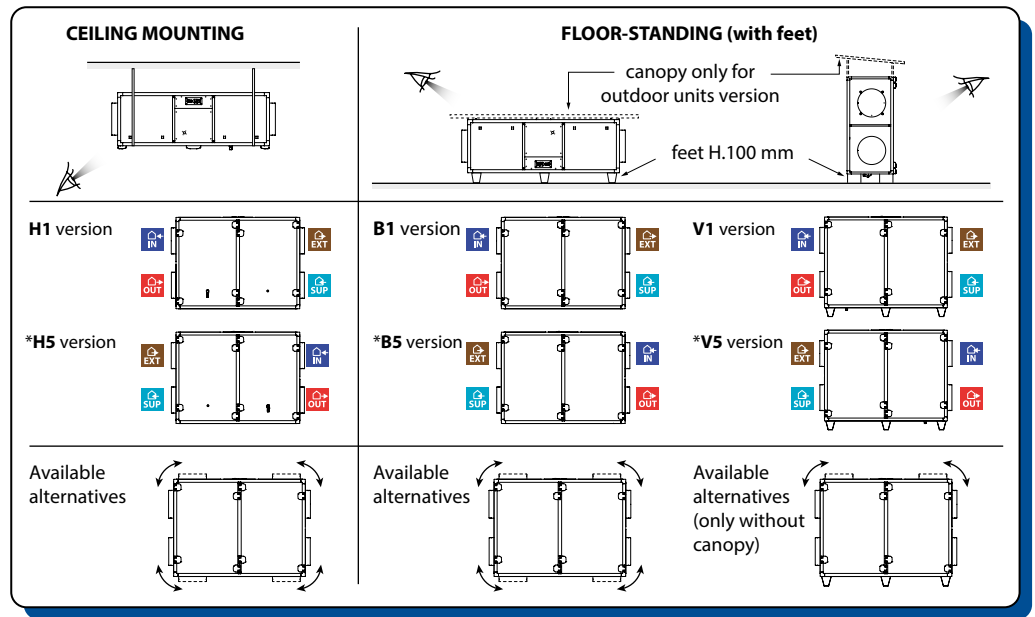

*Versions **H5**, **B5** and **V5** only on order.

NOISE

FAN SPEED	FAN FLOW RATE (m ³ /h)	NOISE RADIATED BY THE BOX (dB)									NOISE TRANSMITTED TO AIR DUCTS (outside air) (dB)								
		L _w dB (A)	63 Hz	125 Hz	250 Hz	500 Hz	1000 Hz	2000 Hz	4000 Hz	8000 Hz	L _w dB (A)	63 Hz	125 Hz	250 Hz	500 Hz	1000 Hz	2000 Hz	4000 Hz	8000 Hz
40%	619	50	41	42	44	45	45	43	38	31	55	46	47	49	50	51	48	43	35
40%	561	49	49	49	46	44	45	43	37	30	54	55	54	52	49	50	48	42	33
40%	496	49	49	49	46	44	45	42	37	29	54	54	55	52	50	50	47	41	32
40%	432	51	49	50	48	47	47	43	37	29	56	54	55	53	53	52	48	41	33
40%	370	52	48	50	49	50	48	44	37	30	58	54	56	55	56	54	49	42	33
40%	304	54	48	50	51	53	50	44	38	30	60	54	56	57	59	56	50	42	33
40%	240	54	48	51	52	53	50	45	38	30	60	54	57	58	59	56	50	43	33
40%	178	55	48	52	53	53	51	46	38	30	61	54	58	59	59	57	51	43	34
40%	79	56	49	53	55	53	52	47	39	31	62	55	60	62	60	58	52	44	34
40%	1	57	50	55	57	54	53	48	41	32	63	55	61	64	61	59	54	45	35
75%	1266	64	54	56	57	59	60	58	54	51	71	61	63	64	66	67	65	61	57
75%	1140	62	50	53	56	57	57	56	53	49	69	56	59	62	64	64	62	59	55
75%	1029	62	58	59	58	56	57	55	52	48	68	65	66	65	63	63	61	58	53
75%	911	61	58	59	58	57	57	54	51	47	68	65	66	65	63	63	61	57	52
75%	794	63	58	60	60	59	58	55	52	47	70	65	67	67	66	65	62	58	53
75%	685	65	58	60	62	62	60	56	52	48	72	65	67	69	69	67	63	58	53
75%	567	67	58	61	64	65	62	57	53	48	74	64	68	71	73	69	64	59	53
75%	452	67	58	62	65	66	63	58	53	48	75	65	69	73	73	70	65	59	54
75%	340	68	58	63	66	66	63	59	54	49	75	65	70	74	74	71	66	60	55
75%	152	69	59	64	69	67	64	60	55	50	77	66	72	77	74	72	67	62	56
75%	2	70	60	66	71	68	65	62	56	51	78	67	74	79	76	73	69	63	57
100%	1672	70	58	61	62	65	65	64	61	59	78	65	68	70	73	73	71	68	66
100%	1502	68	54	57	61	62	63	62	59	57	75	61	64	68	70	70	69	66	64
100%	1353	67	62	63	63	62	62	61	58	56	74	70	71	71	69	69	68	65	62
100%	1334	67	62	64	63	62	62	61	58	55	74	70	71	71	69	69	68	65	62
100%	1198	67	62	64	63	62	62	60	58	55	74	69	72	71	69	69	67	64	61
100%	1046	69	62	64	65	65	64	61	58	55	76	69	72	73	72	71	68	65	62
100%	904	70	62	65	67	68	66	62	59	56	78	69	72	75	76	73	69	66	62
100%	753	72	62	65	69	71	68	63	59	56	80	69	73	77	80	76	70	66	63
100%	605	73	62	66	71	72	68	64	60	57	81	70	74	79	80	76	71	67	63
100%	459	74	63	68	72	72	69	65	61	58	82	70	76	81	80	77	72	68	64
100%	206	75	63	70	75	73	70	67	62	59	83	71	78	84	81	78	74	70	66
100%	3	76	64	71	77	74	71	68	63	60	85	72	80	86	82	80	76	71	67

TECHNICAL DATA SHEET

AEREAULIC PERFORMANCES

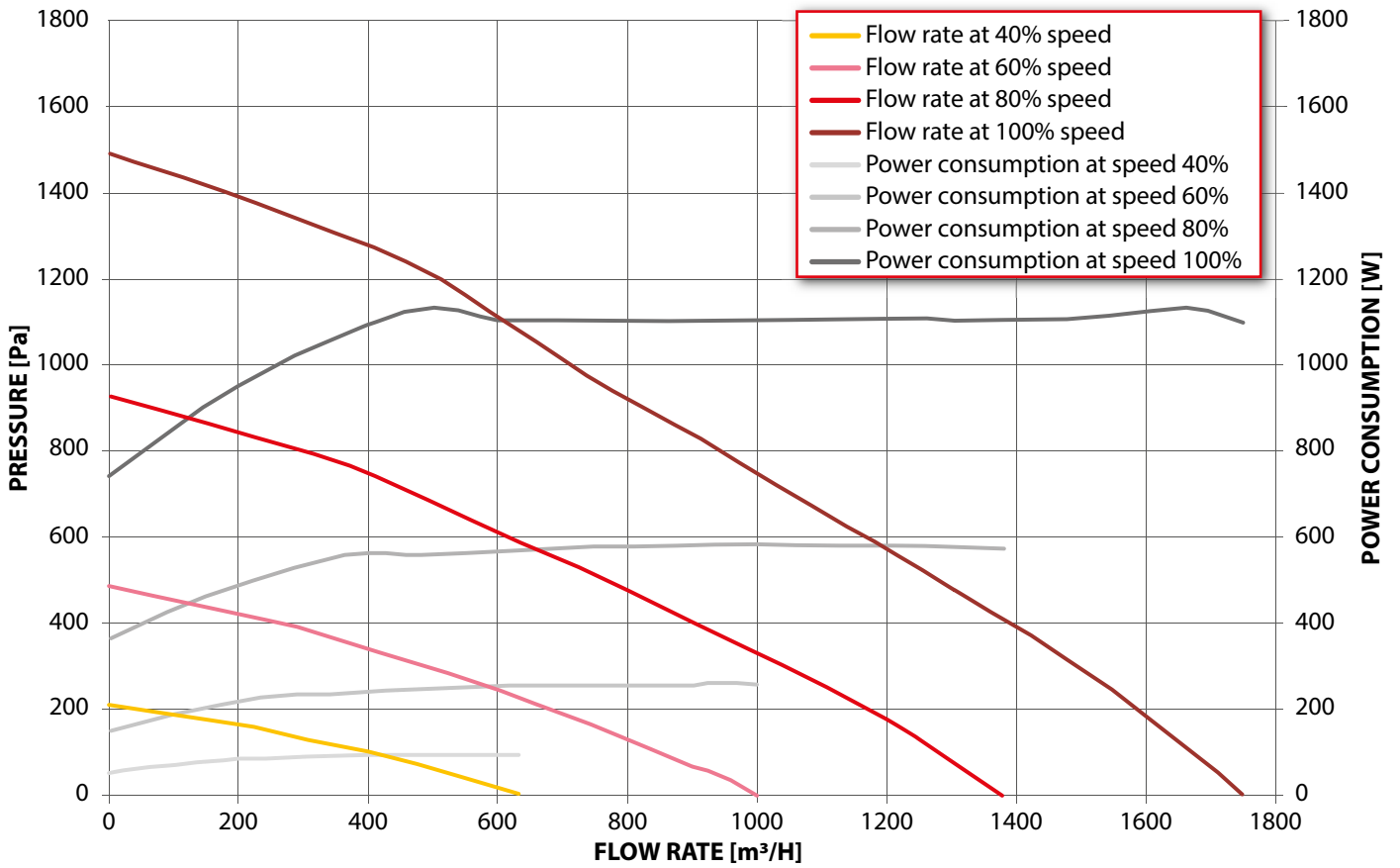

EXCHANGER THERMAL EFFICIENCY

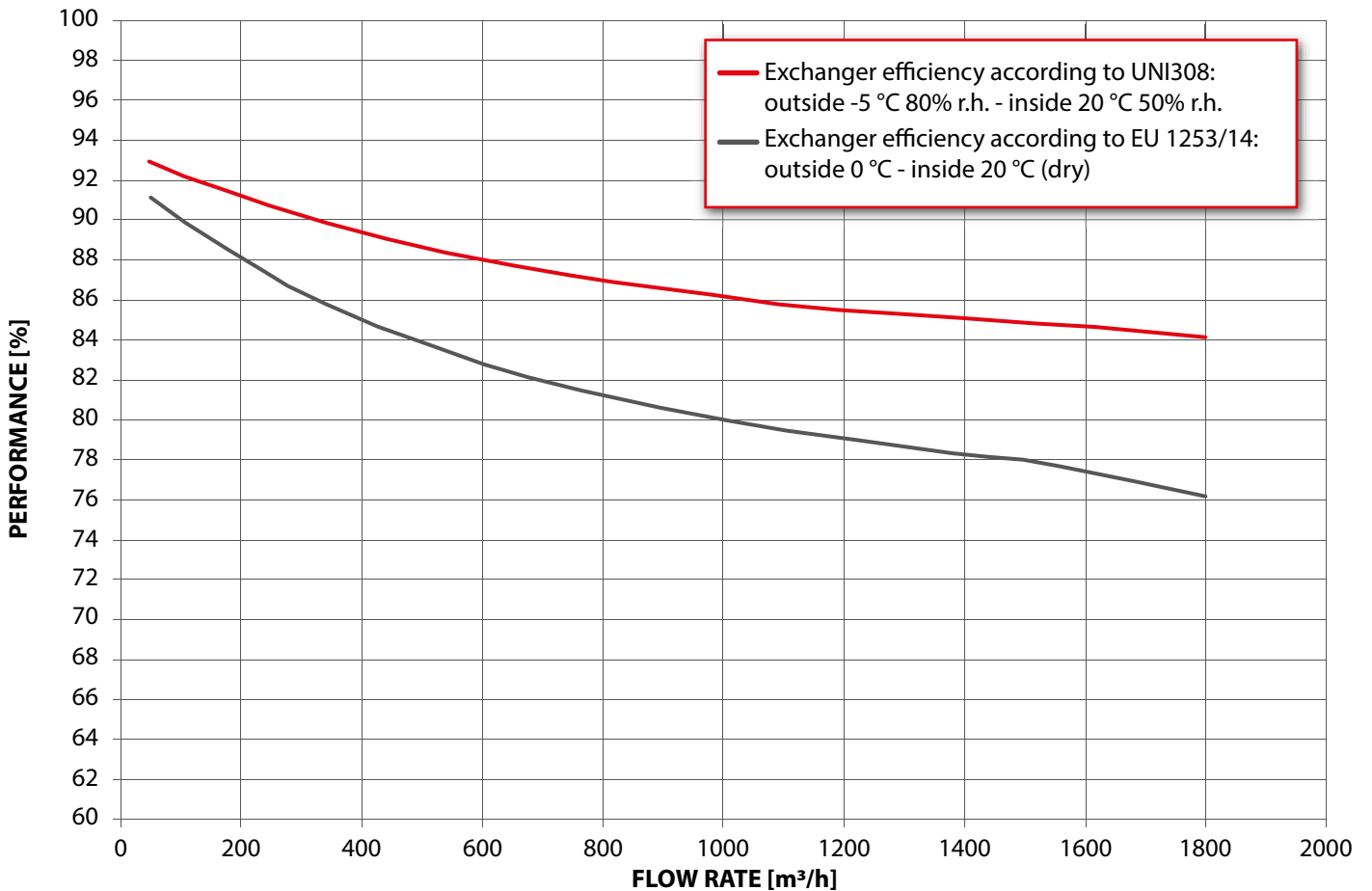

TECHNICAL DATA SHEET

DIMENSIONS

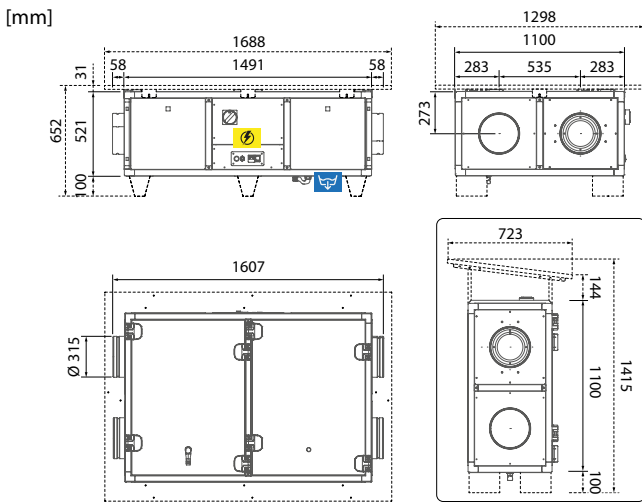

- Wiring box
- Aerulic connections Ø 315 mm
- Condensation drain
- Condensate drain Ø 20 mm

SPACE ALLOWANCES FOR MAINTENANCE/INSPECTION

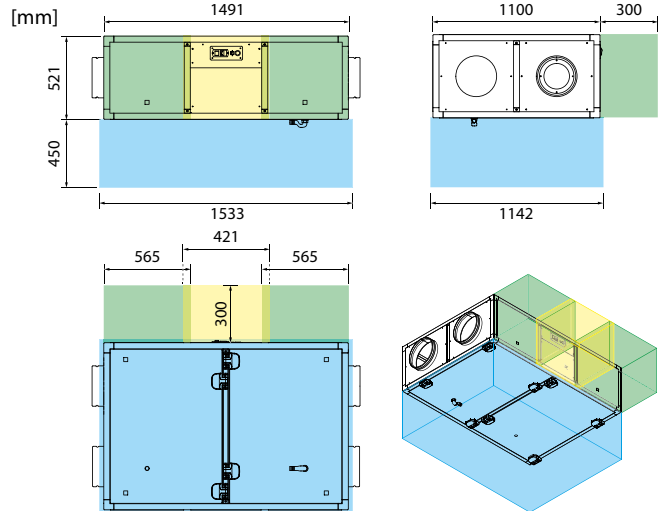

- Unit inspection / exchanger and filter maintenance
- Inspection/maintenance of wiring box
- Filter inspection

PRODUCT SHEET

According to Regulations (EU) No. 1253/2014 and No. 1254/2014 - Data referring to maximum nominal flow rate (for other operating points check the aerulic performance graph).

Supplier's brand	RDZ S.p.A.	
Model identifier	HR 90 1200	
Type of product	UVNR, bidirectional	
Type of motorisation	Variable speed	
Heat recovery system	Countercurrent recuperator	
Heat recovery system thermal efficiency*	75,1%	
Nominal flow rate (m ³ /s)	0,342 m ³ /s	
Effective electric power input (kW)	1,108 kW	
Specific internal ventilation power SFPint (W/(m ³ /s)*	1107 W/(m ³ /s)	
Frontal speed at nominal flow rate (m/s)*	1,74 m/s	
Nominal outside pressure Δps,ext (Pa)	545 Pa	
Internal pressure drop of ventilation components Δps,int (Pa)*	288 Pa	
Fan static efficiency ηs,Fan**	53,9%	
Drawing rate (%)	inside	6,7%
	external	5,6%
	recirculation	not applicabable
Filter classification	Renewal: F7 (ePM1 70%) Revival: M5 (ePM10 50%)	
Location and description of visual signal filter warning signal	Version 3E: signalling LED on remote control	
	Lcd EB version: Alarm shown on remote display	
Sound power level (Lwa in dB(A))*	67 dB(A)	
Internet address with pre-assembly and disassembly instructions	www.rdz.it	

*as per EU Regulation n° 1253/2014

**calculated in accordance with EU Regulation No.327/2011



RDZ S.p.A. 🏠 V.le Trento, 101 - 33077 SACILE (PN) - Italy

☎ Tel. +39 0434.787511 📠 Fax +39 0434.787522

✉ info@rdz.it 🌐 www.rdz.it

FAC0CB033BZ.01

05/2024

COMPANY WITH
QUALITY SYSTEM
CERTIFIED BY DNV
ISO 9001

